



# SAFEJET

## SEAL WATER FILTRATION SYSTEM

Installation, Operation & Maintenance Instructions

### CONTENTS

|  |          |
|--|----------|
| <b>Technical Specifications</b> .....                  | <b>2</b> |
| <b>1. Safety Instructions</b> .....                    | <b>3</b> |
| 1.1 General Safety Instructions .....                  | 3        |
| 1.2 Installation .....                                 | 3        |
| 1.3 Shipment and Transporting .....                    | 3        |
| 1.4 Electricity .....                                  | 3        |
| 1.5 Plumbing .....                                     | 3        |
| 1.6 Civil Engineering .....                            | 3        |
| 1.7 Commissioning .....                                | 3        |
| 1.8 Operation and Control .....                        | 4        |
| 1.9 Maintenance .....                                  | 4        |
| 1.10 Before Returning to Regular Operation .....       | 4        |
| <b>2. Working Principle</b> .....                      | <b>4</b> |
| <b>3. Control Cabinet Functions</b> .....              | <b>5</b> |
| <b>4. Installation and Start-up Instructions</b> ..... | <b>7</b> |
| 4.1 Mechanical .....                                   | 7        |
| 4.2 Electrical .....                                   | 7        |
| 4.3 Start-up .....                                     | 7        |
| <b>5. Maintenance</b> .....                            | <b>7</b> |
| <b>6. Troubleshooting</b> .....                        | <b>8</b> |
| <b>7. Spare Parts</b> .....                            | <b>8</b> |



# SAFEJET

## SEAL WATER FILTRATION SYSTEM

Installation, Operation & Maintenance Instructions

### Technical Specifications – SafeJet 16

#### General Data

|                       |                       |
|-----------------------|-----------------------|
| Maximum Flow Rate     | 42 GPM                |
| Inlet/Outlet Diameter | 2", B16.5-150#        |
| Filtration Degree     | 50 Micron - 2 Candles |
| Design Pressure       | 145 PSIG              |

#### Flushing Data

|                         |                                    |
|-------------------------|------------------------------------|
| Flushing Valve          | 2 X 1"                             |
| Flushing Valve Actuator | Motorized                          |
| Flushing Cycle          | 30 Seconds Per Candle (Adjustable) |
| Drain Connection        | 1-1/4", B36.10 Sch40               |

#### Construction Materials

|                |                           |
|----------------|---------------------------|
| Filter Housing | Stainless Steel 304 / 316 |
| Filter Candles | Stainless Steel 304 / 316 |
| Seals          | EPDM                      |
| Bolts & Nuts   | Stainless Steel           |

### Technical Specifications – SafeJet 23

#### General Data

|                       |                       |
|-----------------------|-----------------------|
| Maximum Flow Rate     | 60 GPM                |
| Inlet/Outlet Diameter | 2-1/2", B16.5-150#    |
| Filtration Degree     | 50 Micron - 2 Candles |
| Design Pressure       | 145 PSIG              |

#### Flushing Data

|                         |                                    |
|-------------------------|------------------------------------|
| Flushing Valve          | 2 x 1"                             |
| Flushing Valve Actuator | Motorized                          |
| Flushing Cycle          | 30 Seconds Per Candle (Adjustable) |
| Drain Connection        | 1-1/4", B36.10 SCH40               |

#### Construction Materials

|                |                           |
|----------------|---------------------------|
| Filter Housing | Stainless Steel 304 / 316 |
| Filter Candles | Stainless Steel 304 / 316 |
| Seals          | EPDM                      |
| Bolts & Nuts   | Stainless Steel           |

### Technical Specifications – SafeJet 33

#### General Data

|                       |                       |
|-----------------------|-----------------------|
| Maximum Flow Rate     | 87 GPM                |
| Inlet/Outlet Diameter | 3", B16.5-150#        |
| Filtration Degree     | 50 Micron - 3 Candles |
| Design Pressure       | 145 PSIG              |

#### Flushing Data

|                         |                                    |
|-------------------------|------------------------------------|
| Flushing Valve          | 3 x 1"                             |
| Flushing Valve Actuator | Motorized                          |
| Flushing Cycle          | 30 Seconds Per Candle (Adjustable) |
| Drain Connection        | 1-1/4", B36.10 Sch40               |

#### Construction Materials

|                |                           |
|----------------|---------------------------|
| Filter Housing | Stainless Steel 304 / 316 |
| Filter Candles | Stainless Steel 304 / 316 |
| Seals          | EPDM                      |
| Bolts & Nuts   | Stainless Steel           |

### Technical Specifications – SafeJet 50

#### General Data

|                       |                       |
|-----------------------|-----------------------|
| Maximum Flow Rate     | 131 GPM               |
| Inlet/Outlet Diameter | 4", B16.5-150#        |
| Filtration Degree     | 50 Micron - 4 Candles |
| Design Pressure       | 145 PSIG              |

#### Flushing Data

|                         |                                    |
|-------------------------|------------------------------------|
| Flushing Valve          | 4 x 1"                             |
| Flushing Valve Actuator | Motorized                          |
| Flushing Cycle          | 30 Seconds Per Candle (Adjustable) |
| Drain Connection        | 1-1/4", B36.10 SCH40               |

#### Construction Materials

|                |                           |
|----------------|---------------------------|
| Filter Housing | Stainless steel 304 / 316 |
| Filter Candles | Stainless Steel 304 / 316 |
| Seals          | EPDM                      |
| Bolts & Nuts   | Stainless Steel           |



# SAFEJET

## SEAL WATER FILTRATION SYSTEM

Installation, Operation & Maintenance Instructions

### 1. Safety Instructions

#### 1.1 General Safety Instructions

- SafeJet filtration products always operate as a component in a larger system. It is essential for the system designers, installers and operators to comply with all relevant safety standards.
- Prior to installation, operation, maintenance or any other type of action carried out on the filter, read this IOM manual carefully.
- During installation, operation or maintenance of the filter, all conventional safety instructions should be observed in order to avoid danger to the workers, the public or to property in the vicinity.
- Please note: The filter enters into flushing mode automatically, without prior warning.
- No change or modification to the equipment is permitted without a written notification given by the manufacturer or by its representative, on the manufacturer's behalf.
- Always observe standard safety instructions and good engineering practices while working in the filter's vicinity.
- Use the filter only for its intended use as designed, any misuse of the filter may lead to undesired damage and may affect your warranty coverage. Please consult with John Crane prior to any non-regular use of this equipment.

#### 1.2 Installation

- Install the filter according to the detailed Installation Instructions provided with the filter by the manufacturer and according to the description given in this manual.
- Make sure to leave enough clearance to enable easy access for future treatments and safe maintenance operations.
- The user should arrange suitable lighting at the area of the filter to enable good visibility and safe maintenance.
- The user should arrange suitable platforms and safety barriers to enable easy and safe access to the filter without climbing on pipes and other equipment. The user should verify that any platform, barrier, ladder or other such equipment is built, installed and used in accordance with the relevant local authorised standards.
- Check and re-tighten all bolts during commissioning and after the first week of operation.
- Use only appropriate standard tools and equipment operated by qualified operators when installing, operating and maintaining the filter.
- When installation is required in hazardous environment sites, underground or high above ground, make sure that the site design and the auxiliary equipment are appropriate and that installation procedures are carried out in accordance with the relevant standards and regulations.
- Ensure walking areas about the installation are slip free when wet.

#### 1.3 Shipment and Transporting

- Shipping and transporting the filter must be done in a safe and stable manner and in accordance with the relevant standards and regulations.
- For shipping, lifting and positioning the filter, use only approved lifting equipment and authorized employees and contractors.

#### 1.4 Electricity

- Electric wiring should be performed by an authorized electrician only, using standardized and approved components.
- Install a lockable main power cut-off switch close to the control panel.
- If due to site constraints, the control panel is installed without a clear line-of sight of the filter, an additional lockable power disconnect cut-off switch should be installed near each filter unit.
- Installation of the filter should be performed to avoid direct water splashing on the electrical components or on the control panel.

#### 1.5 Plumbing

- Extra safety devices should be installed on hot water applications to avoid skin burn danger.
- The user should install a manual water cut-off valve next to the filter's inlet port.
- In cases where the piping network downstream of the filter is pressurized an additional manual water cut-off valve should be installed next to the filter outlet port.
- The user should make sure that the system includes a pressure release / drainage valve to enable release of residual pressure prior to any maintenance procedure performed on the filter.
- The user should make sure that the filter is never exposed to water pressure exceeding the maximum designated pressure for this filter, if needed a pressure reduction valve should be installed upstream of the filter's water inlet port.
- Please note that the maximum working pressure indicated at the filter's specifications table includes the pressure caused by fluid hammer and pressure surge effects.

#### 1.6 Civil Engineering

- Make sure that the filter installation is done by qualified technicians and as per the instructions.
- Make sure that any civil engineering work at the installation site such as construction, lifting, welding, etc. is done by qualified workers / technicians / contractors and in accordance with the relevant local standards.
- While using lifting equipment, make sure that the filter or the lifted part is chained securely and in a safe manner.
- Do not leave lifted equipment if there is no necessity. Avoid working below lifted equipment.
- Wear a safety helmet and safety shoes while using lifting equipment.
- Make sure that the flooring is sloped for drainage and to avoid accumulation of liquids.

#### 1.7 Commissioning

- Carefully read the Commissioning and the First Start-up Operation instructions prior to any attempt to operate the filter.
- In order to achieve maximum performance and smooth operation of the filter it is crucial to perform the Start-up and First Operation procedures exactly as described in this manual.
- Commissioning of the filter shall be done by an authorized technician, do not attempt to commission the filter unaccompanied since this may lead to undesired damage and may affect your warranty coverage.

### 1.8 Operation and Control

- Do not operate the filter before reading carefully and being familiar with its operation instructions.
- Observe the safety stickers on the filter and never perform any operation contradicting the instructions given.
- Never operate or use the filter for purposes other than its original design and intended operation.

### 1.9 Maintenance

Before any maintenance or non-regular operation:

- Servicing the filter should be done only by technicians authorized by John Crane
  - Disconnect the filter from the power supply and lock the Main Power Switch.
  - Disconnect the filter from the water system by closing and securing the Manual Inlet Valve. In cases where the downstream piping network is pressurized, close and secure the Manual Outlet Valve also.
  - Release the residual water pressure by opening the Exhaust Valve.
  - In hot water systems wait till the filter components cool off to a safe temperature.
  - Place warning signs around the work area as required by the local standards and procedures.
  - Inspect the filter's safety stickers and replace any damaged or faded sticker.
  - When working on the filter use only appropriate standard tools.
  - Always open and close valves slowly and gradually.
  - Remove grease and fat material residues in order to avoid slipping.
  - Before disconnecting the filter from the water supply and electricity and before releasing the filter's residual pressure, DO NOT:
    - Loosen or unscrew bolts.
    - remove any protection cover.
    - open any service port flange.
  - Avoid splashing and water leakage to minimize slippage, electrification or damage to the equipment, caused by moisture.
  - While using lifting equipment, make sure that the filter or the lifted part is chained securely and in a safe manner.
  - Wear a safety helmet, goggles, gloves, and any other personal safety equipment required by the local standards and regulations.
  - Manual cleaning of filter element using acid or other chemical agents should be performed in accordance with the relevant material safety instructions, the local standards and regulations and without endangering the operator or his vicinity.
- ### 1.10 Before Returning to Regular Operation
- Re-assemble any protection covers or protection mechanisms removed during service or maintenance operations.
  - Make sure that all the tools, ladders, lifting devices, etc. used during the maintenance procedures are removed and stored away.
  - In order to return the filter to regular operation, follow the First Start-up Operation instructions as detailed in your user manual.
  - If this SafeJet filter is also used in potable water systems, it is required to disinfect the filter according to the local water authority standards and regulations before putting it back to service.

### 2. Working Principle

The SafeJet filter is equipped with filtering candles where the to be filtered water first goes in and then out to the filter chamber. Thanks to 50 micron filtration candles, SafeJet provides a perfect solution against even the smallest suspended solids in your sealing water.

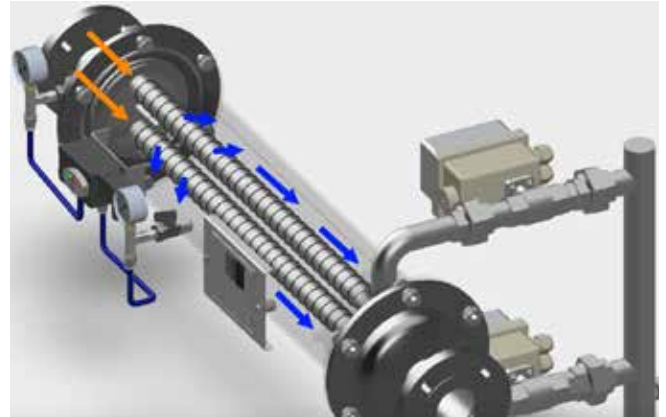

Flushing valves are controlled by the timer or the SafeJet's pressure differential switch (PDS). When the PDS reaches the preset value of 7 PSID, the flushing cycle starts. During the flushing cycle all the particles collected inside the filter candles goes to drain. SafeJet individually flushes all its filtration candles one by one without any interruption to clean water flow to mechanical seal. The flushing cycle can also be activated manually by pressing the test (F1) button from control cabinet screen.

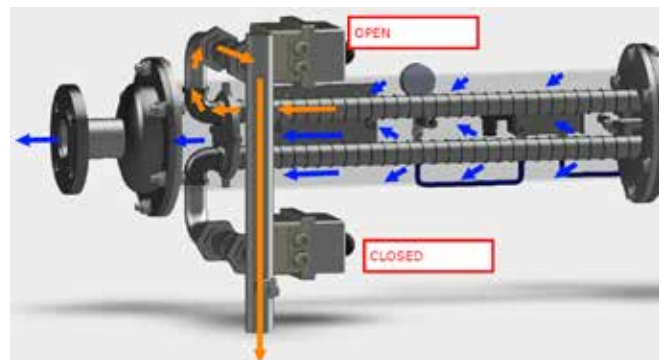
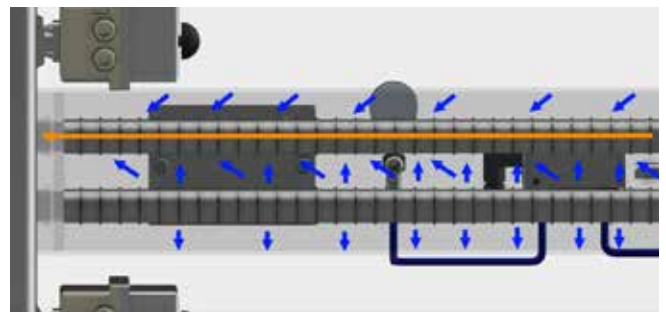

### 3. Control Cabinet Functions

THE CONTROL CABINET IS OPERATED WITH THIS CONTROL PANEL

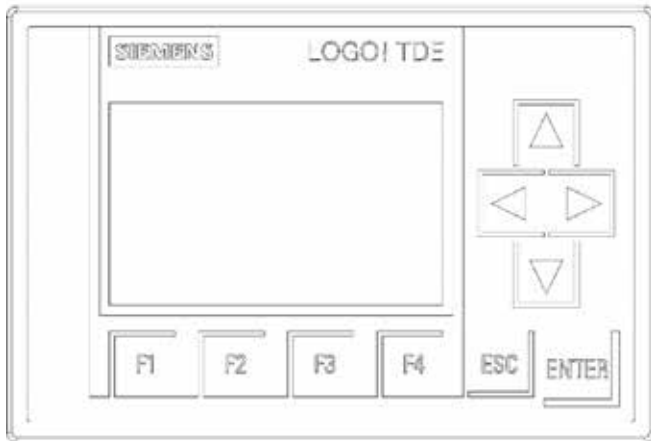

After powering up the Control cabinet, SafeJet will automatically enter to filtering mode.

During Filter mode (indicating filtration time, remaining time for flushing, etc. on screen), press "**DOWN ARROW**," See the Date & Hour page and press "**ESC**."

#### THE STANDARD VIEW IN FILTER MODE



Find "**LOGO! SETTINGS**" line by using "**UP and DOWN ARROWS**", and press "**ENTER**", Find "**PROGMAN**" and find "**SET PARAMETER**" line by using "**UP and DOWN ARROWS**", and press "**ENTER**", Find "**FLT TIME**" line by using "**UP and DOWN ARROWS**", and press "**ENTER**"

Select the number cell which required to be adjusted by using "**LEFT and RIGHT ARROWS**" and press "**ENTER**".

Adjust the numbers for each cells to adjust the required time by using "**UP and DOWN ARROWS**" on blinking cells. After each cell adjustment, press "**ENTER**" to complete adjustment for that cell.

#### About time setting:

10:25s.....(e.g. A)  
10:25m.....(e.g. B)  
10:25h.....(e.g. C)

E.g. A.; "**s**": unit of time is selected as seconds. If "**s**" is selected as time unit and indicated beside the time on the screen, "**10**" indicates the **seconds** and **25** indicates the **milliseconds**."

E.g. B.; "**m**": unit of time is selected as minutes. If "**m**" is selected as time unit and indicated beside the time on the screen, "**10**" indicates the **minutes** and **25** indicates the **seconds**."

E.g. C.; "**h**": unit of time is selected as hours. If "**h**" is selected as time unit and indicated beside the time on the screen, "**10**" indicates the **hour** and **25** indicates the **minutes**."

**FLT TIME** is filtration time between two flushing cycles.

**V1 TIME** is open time of "V1 Flushing Valve" during flushing mode. This time is adjusted as 30 seconds. If needed, this value can be changed.

**V1-2 DLY** is the time delay between V1 and V2 Flushing valves. When flushing process is started, firstly V1 Flushing Valve is opened. At the end of the "V1 Time," V1 Flushing Valve is closed, V1-2 DLY Time is counted, and at the end of the V1-2 DLY Time V2 Flushing Valve is opened.

**V2 TIME** is open time of "V2 Flushing Valve" during flushing mode. This time is adjusted as 30 seconds. If needed, this value can be changed.

**V2-3 DLY** is the time delay between V2 and V3 Flushing valves. (Only for SafeJet 33 and 50)

**V3 TIME** is open time of "V3 Flushing Valve" during flushing mode. This time is adjusted as 30 seconds. In case of requirement this value can be changed. (Only for SafeJet 33 and 50)

**V3-4 DLY** is the time delay between V3 and V4 Flushing valves. (Only for SafeJet 50)

**V4 TIME** is open time of "V4 Flushing Valve" during flushing mode. This time is adjusted as 30 seconds. In case of requirement this value can be changed. (Only for SafeJet 50)

**V1 FAULT** is V1 flushing valve fault time. It takes time for the electrical actuated valves to get opened or closed. If this time takes more than adjusted value, system gives fault. V1 Fault is adjusted as 12 seconds. If needed, this value can be changed. SafeJet's physical valve opening time should be around 10 seconds.

**V2 FAULT** is V2 flushing valve fault time. It takes time for the electrical actuated valves to get opened or closed. If this time takes more than adjusted value, system gives fault. V2 Fault is adjusted as 12 seconds. If needed, this value can be changed. SafeJet's physical valve opening time should be around 10 seconds.



# SAFEJET

## SEAL WATER FILTRATION SYSTEM

Installation, Operation & Maintenance Instructions

**V3 FAULT** is V3 flushing valve fault time. It takes time for the electrical actuated valves to get opened or closed. If this time takes more than adjusted value, system gives fault. V3 Fault is adjusted as 12 seconds. If needed, this value can be changed. SafeJet's physical valve opening time should be around 10 seconds. (Only for SafeJet 33 and 50)

**V4 FAULT** is V3 flushing valve fault time. It takes time for the electrical actuated valves to get opened or closed. If this time takes more than adjusted value, system gives fault. V3 Fault is adjusted as 12 seconds. If needed, this value can be changed. SafeJet's physical valve opening time should be around 10 seconds. (Only for SafeJet 50)

**FLOW SWITCH 1** is the time after which a "FLOW SWITCH FAULT" alarm is given if SafeJet's flow switch detects water flow in drain pipe when flushing valves should be closed. This indicates unwanted water leaking through one of the flushing valves due to jamming or other problem.

**FLOW SWITCH 2** is the time after which a "FLOW SWITCH FAULT" alarm is given if SafeJet's flow switch does not detect water flow in drain pipe when one of the flushing valves should be opened. This indicates a jamming or other failure with one of the flushing valves.

**FLOW WATER FAULT** showing on the screen means that flow switch has triggered an alarm (either no-flow or flow when not allowed). This alarm can be cleared by pressing F2 button.

**VALVE FAULT:** indicated on the screen as "Valve-1 Fault", "Valve-2 Fault" or "Valve-3 Fault" and states in the time period of V1 FAULT, V2 FAULT, V3 FAULT or V4 FAULT time, the related valve did not get opened or closed.

### EXAMPLE PHOTO OF FILTRATION TIME OPTIONS ("FLT TIME")



In options, the [T =] means the set time for given parameter. The [Ta =] means how much time has passed towards the set T

**Filter-1 Flushing On, Set Time, Remaining Time** is indicated on the screen when a flushing cycle is started to inform that V1 Flushing Valve is opened and flushing for 1st filter is being provided. Set Time on same screen states, the adjusted open time value for V1 Flushing Valve. Remaining Time on the same screen states; remaining time for V1 Flushing Valve to get closed.

**Filter-2 Flushing On, Set Time, Remaining Time** is indicated on the screen when a flushing cycle is started to inform that V2 Flushing Valve is opened and flushing for 2nd filter is being provided. Set Time on same screen states, the adjusted open time value for V2 Flushing Valve.

Remaining Time on the same screen states; remaining time for V2 Flushing Valve to get closed.

**Filter-3 Flushing On, Set Time, Remaining Time** is indicated on the screen when a flushing cycle is started to inform that V3 Flushing Valve is opened and flushing for 3rd filter is being provided. Set Time on same screen states, the adjusted open time value for V3 Flushing Valve. Remaining Time on the same screen states; remaining time for V3 Flushing Valve to get closed (SafeJet 33 and 50)

**Filter-4 Flushing On, Set Time, Remaining Time** is indicated on the screen when a flushing cycle is started to inform that V3 Flushing Valve is opened and flushing for 4th filter is being provided. Set Time on same screen states, the adjusted open time value for V4 Flushing Valve. Remaining Time on the same screen states; remaining time for V4 Flushing Valve to get closed (SafeJet 50)

**F1 Button on Panel:** A flushing cycle can be started manually for the filter by pressing F1 Button on Panel. V1, V2, V3 (SafeJet 33 and 50) and V4 (SafeJet 50) Flushing Valves provides flushing respectively according to adjusted time values.

**F2 Button on Panel:** Fault reset button; in case of a fault situation, software should be reset by pressing F2 Button on panel after the problem is solved. F2 Button on panel can be used to stop a flushing cycle too.

**F3 Button on Panel:** by pressing to F3 Button on panel for 3 seconds, counters (time started flushing cycles, DP started flushing cycles) can be reset.

**Power On Light on Control cabinet:** Activated light indicates CB is powered and 24VDC is active.

**Valve-1 Open Light on Control cabinet:** Activated light indicates V1 Flushing Valve is opened.

**Valve-1 Closed Light on Control cabinet:** Activated light indicates V1 Flushing Valve is closed.

**Valve-2 Open Light on Control cabinet:** Activated light indicates V2 Flushing Valve is opened.

**Valve-2 Closed Light on Control cabinet:** Activated light indicates V2 Flushing Valve is closed.

**Valve-3 Open Light on Control cabinet:** Activated light indicates V3 Flushing Valve is opened. (SafeJet 33 and 50)

**Valve-3 Closed Light on Control cabinet:** Activated light indicates V3 Flushing Valve is closed. (SafeJet 33 and 50)

**Valve-4 Open Light on Control cabinet:** Activated light indicates V4 Flushing Valve is opened. (SafeJet 50)

**Valve-4 Closed Light on Control cabinet:** Activated light indicates V4 Flushing Valve is closed. (SafeJet 50)

**Valve Fault Light on Control cabinet:** Activated light indicates a fault on one of the valves. This light is activated by common signal from flushing valves.

**Flow Water Fault light on Control cabinet:** Activated light there is a Flow Switch fault exist on the system (Flow Switch is activated when it is not required to be activated or Flow Switch is not activated when it is required to be activated).



# SAFEJET

## SEAL WATER FILTRATION SYSTEM

Installation, Operation & Maintenance Instructions

### 4. Installation and Start-up Instructions

#### 4.1 Mechanical

- Select a convenient location for the installation of the filter where operation and maintenance will be optimum.
- It is recommended to prepare a beam or any other arrangement which will allow hanging a crane for opening the filter.
- Install the filter vertically or horizontally.
- Make sure that the direction of the flow is as indicated by the arrow marked on the filter housing or specified on the drawing.
- If possible, prior to installing the filter, flush the main line to remove large objects which may damage the filter's internal mechanism.
- Install a drainage pipe to the exhaust valve. Please note that no restriction is allowed on the drainage pipe. For special applications, please consult the manufacturer.

#### 4.2 Electrical

- Connect the appropriate electrical power supply to the control board and the interconnections between the control board and the electrical components on the filter, according to the wiring diagram provided.
- Install fuses as noted on the electrical schematic and ensure that all electrical connections are well insulated.

#### 4.3 Start-up

- Make sure you have at least 30 psig water pressure, but no more than 145 psig.
- Switch on the main circuit breaker.
- Slowly open the valve at the inlet of the filter. If possible, with an outlet valve closed and a by-pass valve open, and repeat a manual flushing (F1 button).
- Open the outlet valve gradually and bring the filter to normal working condition.
- The cleaning operation should be for 30 seconds and full flow out of the exhaust valve should be observed during this entire period. After the 30 seconds cleaning operation, the flow out of the exhaust valve should stop immediately. Be sure to observe that there is no significant leakage occurring from the exhaust valve once the cleaning operation has completely stopped.

### 5. Maintenance

Before beginning any maintenance procedure, carefully read the safety instructions of this SafeJet IOM manual and make sure that all the workers at the filtration site are fully aware of and comply with these and any other local safety instructions.

#### General inspection of the SafeJet filter operation

This is the visual basic general inspection procedure of the filter for proper operation. It should be done regularly and prior to any scheduled maintenance procedure.

Initiate a self-cleaning cycle; Check that all exhaust valves open.

#### Weekly Maintenance

##### Visual Check:

1. Check that the filter operates properly by following the General Inspection of the Filter Operation as described above.
2. Visually check the filter housing and the valves for leakage.
3. Check the filter for loose bolts.

##### Maintenance prior to long term cessation of filter operation

The following must be done if the SafeJet filter will not be in operation for more than a month.

1. Operate a flushing cycle (If possible, with a closed downstream valve).
2. Disconnect the control board from the power supply.
3. Release pressure from the filter.

##### Maintenance prior to re-operation

1. Connect the control board to the mains.
2. Check proper operation of the filter.

#### Every Twelve Months

Before beginning this maintenance procedure, carefully read the safety instructions of this IOM manual and make sure that all the workers at the filtration site are fully aware of and comply with, these and any other local safety instructions.

1. Perform a General Inspection of the filter Operation as described above and carefully inspect the filter visually for:
  - a. Proper operation
  - b. Any leakage from the filter housing or accessories
  - c. Abnormal or unusual noises
  - d. Loose bolts
  - e. Any sign of corrosion on the filter housing or accessories
  - f. Unusual vibrations
  - g. Non-smooth operation of the filter valves
2. Close the inlet and the outlet valves of the filter. Drain the filter housing and release any residual pressure.
3. Disconnect and lock the filter's power supply.
4. Release any residual pressure.
5. Dismantle the filter.
6. Inspect the filter screen and components for any wear and tear.
7. Check the filter housing and lid for any sign of corrosion.
8. Check the filter internal and external coating and paint for damage.
9. Replace any damaged component.
10. Make sure that your maintenance engineers are aware of even the slightest sign of corrosion in the filter housing, lid or accessories. In such case consider performing a standard pressure vessel test as required by your local applicable standards.
11. Re-assemble the filter.
12. Perform a complete COMMISSIONING, START-UP AND FIRST OPERATION as described earlier in this document.





# SAFEJET

## SEAL WATER FILTRATION SYSTEM

Installation, Operation & Maintenance Instructions

### 6. Troubleshooting

| No. | Fault  | Type of fault   | Correcting the fault   |
|-----|--|---|--|
| 1   | Filter flushes every 5 minutes or even shorter intervals.      | Filter candles are not cleaned by the flushing operation, or electrical short circuit at the PD unit. It is also possible that raw water quality has changed (more suspended solids than before). | Check the filter inlet and outlet pressure. If the difference is more than 7 PSID, carry out several flush operations and recheck the pressures. If the difference is still more than 7 PSID, physically remove and inspect the candles, and repair them as required. If the pressure differential is less than 7 PSID, the fault is caused by an electrical short circuit. Call your electrician. Refer to schematic drawing. |
| 2   | Exhaust valve does not operate when cleaning operation occurs. | Actuator malfunctions.  | Dismantle the actuator, clean all water passages and ensure all electrical connections are made and functioning properly. If the actuator still malfunctions, fix or replace the actuator.   |
| 3   | Water flow discharged from the waste exhaust pipe is too low.  | Restrictions in the waste exhaust piping system.  | Inspect the waste exhaust piping system and locate the causes of any restriction and remove them.  |

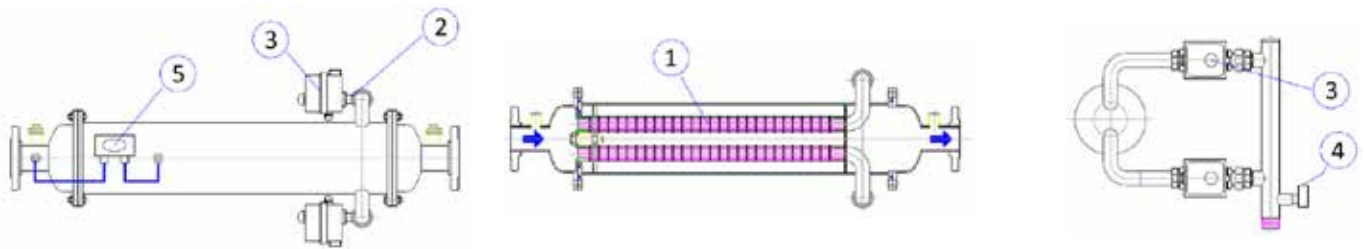

### 7. Spare Parts

- 1 Filter candle 50 micron (2 pcs for SF16 and SF23, 3 pcs for SF33 and 4 pcs for SF50)
- 2 Flushing valve (2 pcs for SF16 and SF23, 3 pcs for SF33 and 4 pcs for SF50)
- 3 Electronic actuator for flushing valve (2 pcs for SF16 and SF23, 3 pcs for SF33 and 4 pcs for SF50)
- 4 Flow switch (1 pc all models)
- 5 Differential pressure gauge / switch (1pc all models)



**North America**  
United States of America  
Tel: 1-847-967-2400

**Europe**  
United Kingdom  
Tel: 44-1753-224000

**Latin America**  
Brazil  
Tel: 55-11-3371-2500

**Middle East & Africa**  
United Arab Emirates  
Tel: 971-481-27800

**Asia Pacific**  
Singapore  
Tel: 65-6518-1800

If the products featured will be used in a potentially dangerous and/or hazardous process, your John Crane representative should be consulted prior to their selection and use. In the interest of continuous development, John Crane Companies reserve the right to alter designs and specifications without prior notice. It is dangerous to smoke while handling products made from PTFE. Old and new PTFE products must not be incinerated. ISO 9001 and ISO14001 Certified, details available on request.

**smiths**  
bringing technology to life

©2024 John Crane 07/24 [johncrane.com](http://johncrane.com)



IOM SafeJet-US