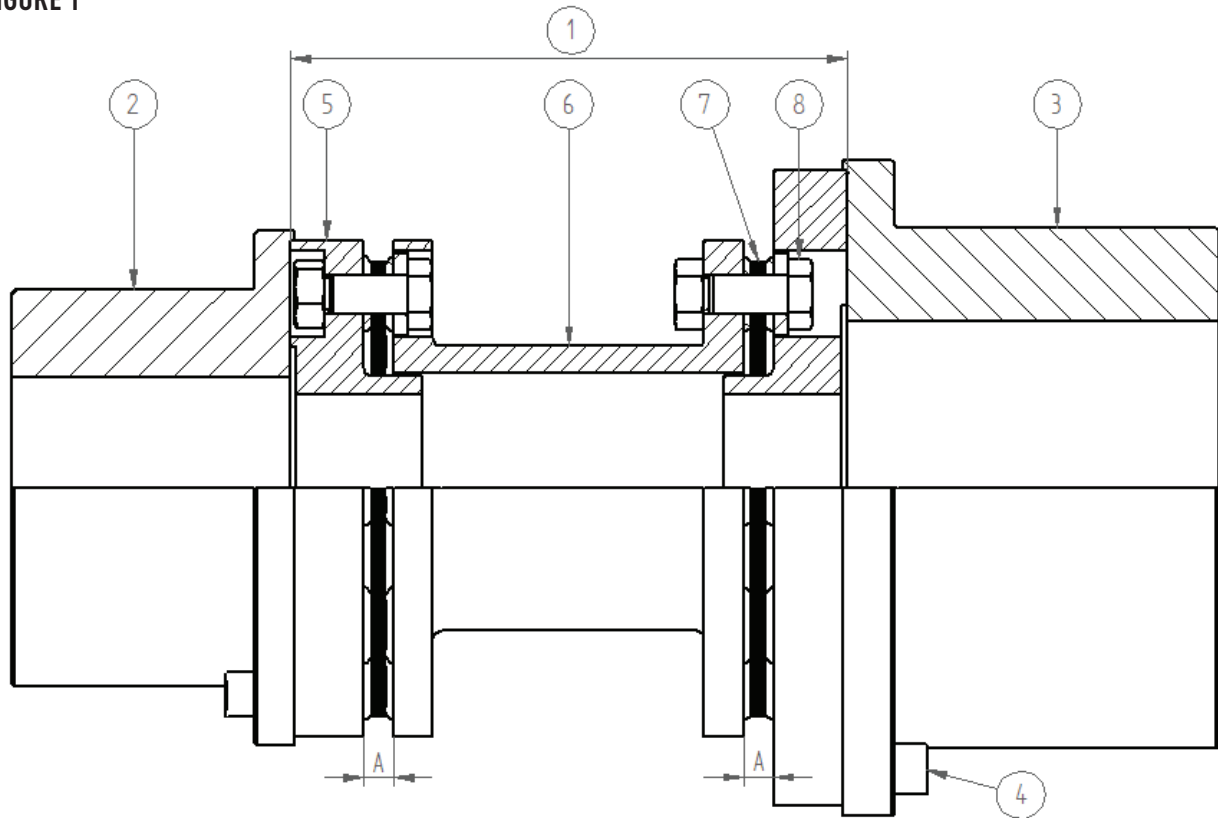

FIGURE 1



- | | |
|---|--|
| 1 – Transmission unit | 6 – Spacer |
| 2 – Standard hub -external location | 7 – Membrane pack |
| 3 – Extended hub -external location [sizes 0300 - 2000] | 8 – Drive-bolt assembly (drive bolt, locknut, washers and overload collar) |
| 4 – Hub bolt | |
| 5 – Guard ring | |

Foreword

These instructions are provided to familiarize the user with John Crane's Metastream TLKS coupling and its designated use. These instructions must be followed whenever work is carried out on the coupling and should be kept available for future reference.

ATTENTION These instructions are for the fitting, operation and maintenance of the coupling as used in rotating equipment and will help to avoid danger and increase reliability. The information required may change with other types of equipment or installation arrangements. These instructions must be read in conjunction with the instruction manuals for both the driver and driven machinery.

If the coupling is to be used for an application other than that originally intended or outside the recommended performance limits, John Crane must be contacted before its installation and use.

Any warranty may be affected by improper handling, installation or use of this coupling. Contact John Crane for information as to exclusive product warranty and limitations of liability.

If questions or problems arise, contact your local John Crane sales/service engineer or the original equipment manufacturer, as appropriate.

ATTENTION John Crane couplings are precision products and must be handled appropriately. Take particular care to avoid damage to spigots, mating faces, hub bores, keyways and membranes. Do not excessively compress the coupling membranes during assembly. Refer to Table 1 for compression limits (Min gap 'X').

These instructions are written for standard catalog products, generally designed in accordance with the drawing shown.

Safety Instructions

The following designations are used in the installation instructions to highlight instructions of particular importance.

IMPORTANT is used for items of particular concern when using the coupling.

ATTENTION where there is an obligation or prohibition concerning the avoidance of risk.



where there is an obligation or prohibition concerning harm to people or damage to the equipment.

The usual extent of supply comprises:

- A factory-assembled transmission unit (1) comprising
 - 2-off guard rings (5)
 - 1-off spacer (6)
 - 2-off membrane packs (7)
 - 16-off drive bolt assemblies (8) *consisting of drive bolt and nut, overload collar and washers*
- Driver hub (2, 3)
- Driven hub (2, 3)
- 2 sets of hub bolts (4) to secure the transmission unit between the two hub flanges

IMPORTANT If a general arrangement drawing is supplied with the coupling, then all data indicated on that drawing takes precedence over information included in these instructions.

Storage

If the coupling is not to be used immediately, it should be stored indoors or in a waterproof container away from direct heat in its original packing.

All documentation supplied with the coupling should be retained for future reference.

Spares

When requesting spares, always quote the full designation of the coupling (e.g., TSKS-0120-0177-1500).

The following spares can be purchased from John Crane:

- Set of hub bolts (4) ****please specify standard and/or extended hubs****
- Hubs, bored to your requirement or unbored (2, 3)
- Complete transmission unit, balanced or unbalanced (1)
- Guard ring assembly (0=kit), including
 - Membrane pack (7)
 - 8-off drive bolt assembly (8) **consisting of drive bolt and nut, overload collar and washers**
 - Guard ring (5)

Installation

Remove the coupling from the packaging and carefully inspect for signs of damage. Pay particular attention to the hub bores and the spigot/recess location features, which should be free from burrs and other damage.

Installation of hubs



Prior to installing the coupling, ensure that the machinery is made safe. Hubs must be adequately supported during installation to avoid accidental damage should they slip.

Parallel bore with keyed drive

1. Ensure the hub bore and mating shaft are clean.
2. The hub is usually installed with the hub face and shaft end flush.
3. Measure the shaft diameter and hub bore to confirm the correct fit.
4. For clearance fits, install the key(s) into the shaft keyway and with a little lubrication on the shaft, slide the hub onto the shaft. The key should be a tight sliding fit in the keyway with a small clearance at the top of the key. Secure the hub to the shaft in the correct axial position with one or more grub screws.
5. John Crane recommends a light interference fit for most applications, and it may be necessary to apply heat to assist fitting of such hubs. A warm oil bath will usually be adequate. DO NOT spot heat or exceed 175°C as this may cause distortion. A thermal heat stick can be used to estimate the temperature before quickly sliding the hub onto the shaft. A suitable stop will ensure the correct axial position is located.

Taper bore with keyed drive (see Figure 4)

1. Thoroughly clean all contact surfaces and smear the tapered surfaces with oil.
2. Fit the hub onto the shaft without the key(s). Lightly hammer the hub with a soft-faced mallet to ensure metal-to-metal contact takes place.
3. Measure the distance from the end of the shaft to the face of the hub using a depth micrometer (record this measurement).
4. Securely mount a dial gauge onto the inboard hub flange and set to zero.
5. Remove the hub and fit the key(s), which should be a tight sliding fit in the keyway with a small clearance at the top of the key.
6. Refit the hub and draw up the shaft to the correct axial position indicated by the dial gauge. If an interference fit is required the hub may have to be heated.
7. When the hub has cooled re-measure the distance from the end of the shaft to the face of the hub to confirm the correct axial position.
8. Fit the shaft-end retaining nut if applicable to ensure the hub is locked in position axially.

NOTE: The hub face may not be flush with the shaft end when taper bores are used.

Taper hubs mounted by oil injection (see Figure 4)

1. Ensure that fillets and corner radii of mating surfaces, oil distribution and drainage grooves are well rounded and free from burrs.
2. Thoroughly clean all contact surfaces and smear the tapered surfaces with oil.
3. Fit the hub onto the shaft. Lightly hammer the hub with a soft-faced mallet to ensure metal-to-metal contact takes place.
4. Measure the distance from the end of the shaft to the face of the hub using a depth micrometer (record this measurement).
5. Securely mount a dial gauge onto the inboard hub flange and set to zero.
6. Fit the oil injection equipment, axial stop and mounting tools. Consult the arrangement drawing and the oil injection system suppliers' instructions.



Fit and secure the axial ram or hydraulic nut BEFORE injecting oil between the components.

7. Inject oil between the components until the required mounting pressure is reached, or it leaks out at the ends of the mating surfaces.
8. By means of the mounting tools, draw the hub up the shaft to the correct axial position, injecting oil during this operation. **NOTE:** The correct pull-up distance should be shown on the hub drawing.
9. Release the oil pressure and leave equipment fitted for one hour to allow for oil to drain from mating surfaces.
10. Remove the mounting tool and oil injection equipment.
11. Re-measure the distance from the end of the shaft to the face of the hub to confirm the correct pull-up.
12. Fit the locking washer and shaft-end retaining nut if applicable.



WAIT for 3-4 hours before applying torque.

FIGURE 4

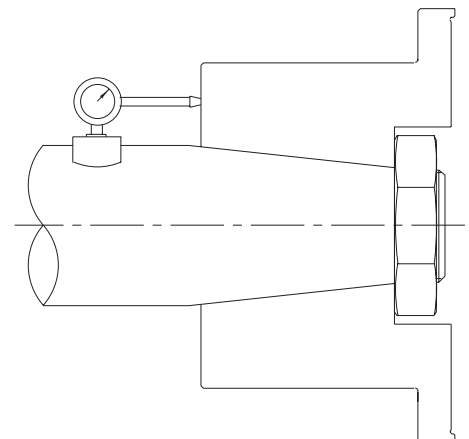

Unbored hubs

John Crane recommends a light interference fit for keyed hubs and shafts (e.g., a K7/m6 fit). The finished bore size can be calculated from the measured shaft diameter.

When setting up the hub to machine the bore use the hub location recess and face as datum surfaces, as shown in Figure 5.

The hub face should be set such that the maximum runout does not exceed 0.00008mm per mm of hub flange diameter or 0.025 mm TIR, whichever is greater. The hub location recess should be set so the maximum runout does not exceed 0.00008mm per mm of recess diameter or 0.012 mm TIR, whichever is greater. Please note that for API 671 applications the required tolerances will be tighter.

FIGURE 5

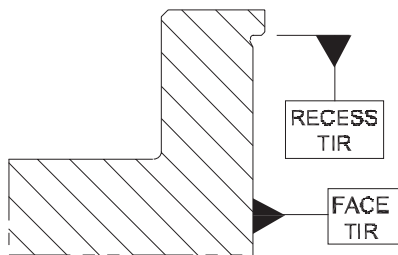

Adapters

For machines having an integral flanged shaft, the flange may be machined to suit the bolting configuration of the coupling transmission unit. Alternatively, the coupling may be supplied with a customized flange adapter. Refer to the specific general arrangement drawing for location and mounting details.

Shaft Alignment

Align the center lines of the driving and driven machine shafts as follows:

1. Move the equipment into position.
2. Check for any soft foot and correct before commencing alignment.
3. With one machine firmly bolted down, set the distance between shaft ends (DBSE) according to the drawing or catalog dimension.

IMPORTANT DBSE should be measured between the inner face of the hubs and should not be taken as the length of the transmission unit at its outer periphery. DBSE may not be equal to the precise distance between shaft ends. In particular, the faces of tape-bored hubs may not be flush with the shaft end (refer to Figure 6).

4. Align the shaft center lines both horizontally and vertically, ideally using the shafts. However, if access prohibits this then align using the hub bosses or flanges. John Crane recommends the reverse periphery method for accurate alignment. This can be done using dial gauges or with a laser shaft alignment kit. Further details on recommended laser alignment vendors are available from John Crane on request.

5. Recheck the DBSE after the shafts have been aligned.

6. Axial shims (together with a shim carrier in some cases) may be supplied on applications where it is difficult to accurately set a predetermined shaft end separation (DBSE). This is often the case where one or both of the hubs are taper bored. Where this feature is supplied, the thickness of shims (plus carrier, if applicable) are added to the free length of the transmission unit so that the combined length is equal to the measured distance between the hub flange faces, making any allowance for known shaft movements.

NOTE: It is best to measure the transmission unit when it is in a gagged condition.

IMPORTANT The misalignment tolerances quoted in literature and on drawings allow for dynamic conditions and variations. For the best service from the coupling, John Crane recommends that installed misalignment is no more than 10% of the maximum allowable misalignment, with allowance being made for any anticipated movements which will occur during operation (e.g., thermal movements on hot pumps).

FIGURE 6

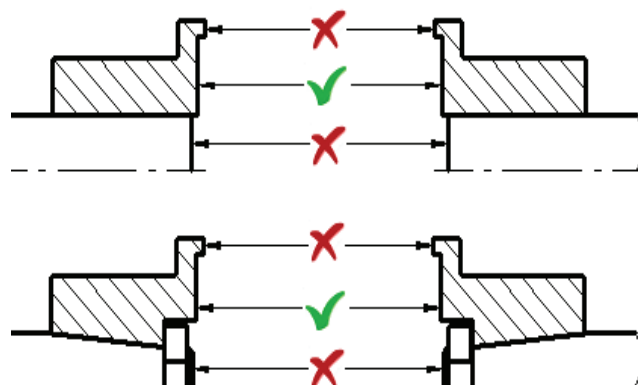

Installation of the Transmission Unit

1. Check spigot and recess locations on the hubs and transmission unit for damage.



The transmission unit must be adequately supported during installation to avoid accidental damage should it slip.

2. Compress the transmission unit then slide it between the hubs. To allow for compression using hub bolts (4), the spacer flanges (6) are drilled to allow the bolts to be threaded into the guard ring (5) as shown in Figure 7. For DBFF's less than the preferred minimum, spacer flanges are slotted. Tightening evenly, compressing the transmission unit until clearance between the hub spigots and transmission unit length is achieved, allowing installation. Do not over compress the transmission unit as this can damage the metal membrane elements. The minimum gap 'X' (see Figure 7) should not be less than the values shown in Table 1, unless indicated otherwise on the general arrangement drawing.

IMPORTANT Always remove the compression bolts as soon as the transmission unit is in position.

3. Align the hub/transmission unit flanges if they have been match marked.
4. Fit the hub bolts by hand initially, then tighten evenly to locate the transmission unit, ensuring the spigots enter their recesses squarely. Using a torque wrench tighten in a "diametrically opposite" sequence to the torque values shown in Table 1 (tightening torque relates to lubricated bolts).
5. Measure dimension 'A' (see Figure 1) on the transmission unit. Check against the nominal value with the +/- tolerance applied, both of which are given in Table 1. If outside these limits, redo the axial alignment.
6. Rotate the machinery two or three times slowly to ensure it moves freely.

Maximum angular misalignment = 0.33 degrees to 3600rpm and 0.25 degrees above 3600rpm.

FIGURE 7

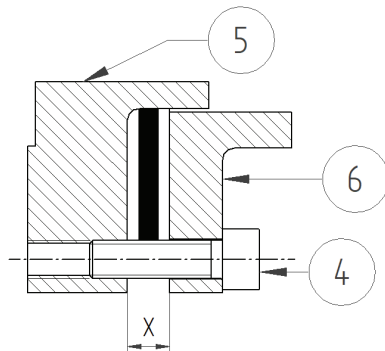

Operation, Inspection and Maintenance



Before starting the machinery, ensure that all necessary safety procedures are being observed and coupling guards are fitted.

Routine examination should include a periodic check on the tightness of fasteners and visual inspection of transmission unit components for signs of fatigue or wear.

If the coupled machinery is disturbed at any time, shaft alignment should be rechecked. Alignment checking is recommended if a deterioration of installation alignment during service is suspected.



Maintenance work must only be carried out by suitably qualified personnel when the equipment is stationary and has been made safe.

John Crane flexible power transmission couplings are designed and selected to give an unlimited service if used within the parameters for which they are specified. Failures are rare and can generally be attributed to excessive misalignment, severe overload or a combination of both. In all cases of coupling failure, it is advisable that the cause of failure is first identified and corrected.

Failure of the coupling will generally be failure of a membrane assembly.

Transmission Unit Refurbishment

It is recommended that a transmission unit is the minimum spare ordered, in order to ensure that the quality of transmission unit assembly is maintained.

To replace the transmission unit, remove the hub bolts and then withdraw the transmission unit using the compression bolts feature in the spacer, as appropriate.



The transmission unit must be adequately supported during removal to avoid accidental damage should it slip.

ATTENTION When repairing John Crane flexible membrane couplings, only John Crane approved parts should be used.

NOTE: For balanced TLK spacer couplings, the transmission unit is usually supplied as a factory assembled unit that should not be dismantled. However, when used at low or medium speeds, the transmission unit can be reconditioned but will require rebalancing.

Guard ring assembly units (O-kits) should be replaced in pairs, failure of one will usually result in damage to the other.

T SERIES FLEXIBLE MEMBRANE COUPLING FOR API APPLICATIONS

Installation, Operation & Maintenance Instructions

TABLE 1

Coupling Size	Standard Hub Bolt Size	Standard Hub Bolt Tightening Torque * Nm	Large Hub Bolt Size	Large Hub Bolt Tightening Torque * Nm	Min Gap 'X' mm	Coupling Max Axial Deflection +/- mm	Dim'n 'A' (Nominal) mm	Dim'n 'A' (+/- Tol.) mm	Hub Jacking Bolt Size
0300	M8	35	M12	120	9.1	1.4	10.20	0.10	M6
0500	M10	65	M12	120	9.4	1.7	11.05	0.15	M6
0750	M12	120	M14	180	10.1	1.9	11.75	0.15	M6
1050	M12	120	M14	180	10.7	2.2	12.50	0.20	M6
1500	M14	180	M16	280	11.9	2.4	14.00	0.20	M8
2000	M16	280	M16	280	13.4	2.7	15.60	0.20	M8
2600	M16	280			14.6	3.0	16.95	0.25	M8
3350	M14	180			15.3	3.2	17.95	0.25	M8
4250	M14	180			16.1	3.5	18.90	0.30	M8
6010	M16	280			17.3	3.9	20.40	0.30	M8
8500	M16	280			19.8	4.4	23.35	0.35	M8
9013	M16	280			23.1	5.0	27.10	0.40	M8
9017	M16	280			25.2	5.5	29.60	0.40	M16
9021	M16	280			28.1	6.0	32.90	0.50	M16
9036	M16	280			34.3	7.1	39.95	0.55	M16
9049	M16	280			37.7	7.9	44.05	0.65	M16

* tightening torque for lubricated bolts

Guard Ring Assembly Unit (O-kit) Replacement

1. Remove the drive bolts (8B) and nuts (8N), and remove the guard ring assembly from the spacer piece. Do not attempt to dismantle the guard ring assembly any further.
2. Identify the fasteners on the new guard ring assembly, which attach to the spacer flanges, and remove the loosely assembled nuts (8N).
3. With the bolts (8B) in position, carefully press on the bolt heads to push them into the spacer evenly.
NOTE: Light hammering with a soft mallet may be required, but ensure assembly is even so as not to over-strain the flexible membranes.
4. Place a small amount of thread-locking compound (e.g., Loctite 242 or equivalent) on the protruding bolt threads and then assemble the nuts (8N). Holding the bolts firmly, turn the spacer nuts evenly to the correct tightening torque value given in Table 2.
5. Complete the refurbishment of the transmission unit by replacing the second guard ring assembly unit.

TABLE 2. Standard Tightening Torques

Coupling Size	Tightening Torque Nuts (8N)
	Nm
0300	65
0500	105
0750	160
1050	225
1500	305
2000	425
2600	525
3350	525
4250	785
6010	1095
8500	1860
9013	2400
9017	3700
9021	4450
9036	7200
9049	10700

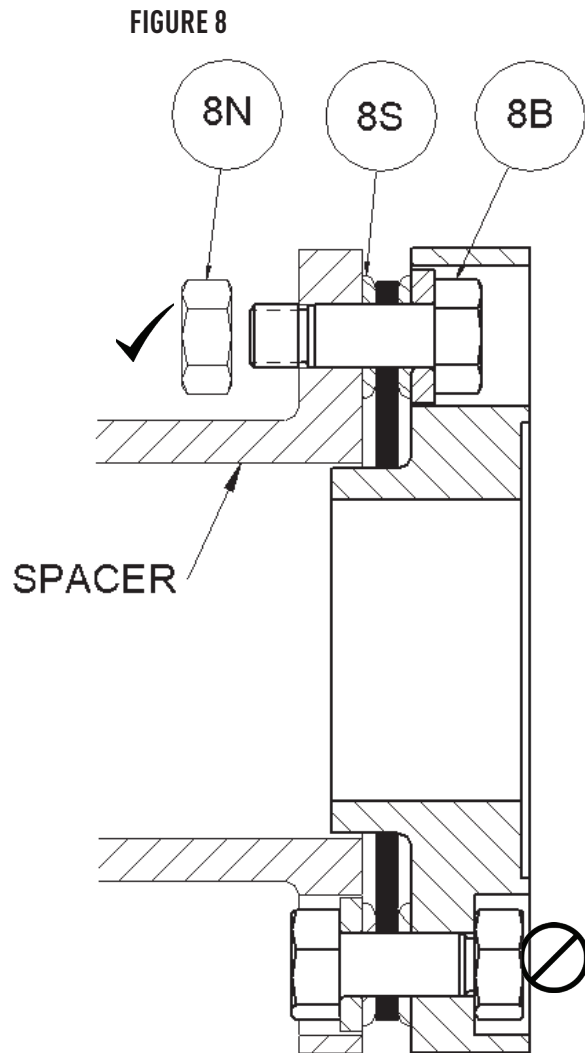

Image indicative of TLKS Coupling

The respect of the Essential Health and Safety Requirements is ensured by conformity with:

EN ISO 80079-36 : 2016

EN ISO 80079-37 : 2016

CE / ATEX Marking

All couplings that comply with CE and ATEX legislation will be marked as shown. Zone and Category may be subject to change upon customer request. This will be etched on the spacer element of the transmission unit if enough room is available. Marking has to be readable and indelible; it has to include the following indications:

- o CE Stamp
- o Manufacturing site address
- o Coupling part number
- o INERIS Certificate Reference
- o (Serial number)
- o (Year of construction)
- o II 2 GD OR I M1
- o Ex h IIC T(*) Gb or
- o Ex h IIIC T(*) Db or
- o Ex h I T150°C
- o T. Ambient : (*)

(*) : see Table 4 below.

EXAMPLES

CE Ex II 2 GD Ex h IIC T3 – Ex h IIIC T200°C 76250, France.

TSKS-0055-0055-1000

INERIS 20ATEX3006, xxxxx, 2020

Or

CE Ex I M1 Ex h I T150°C 76250, France.

TSKS-0120-0033-1000

INERIS 20ATEX3006, xxxxx, 2020

ATTENTION

For maximum ambient temperature above 90°C, use in mining is not authorized.

Marking may be carried out in the language of the country of use.

The protective system or equipment has to additionally carry the marking normally stipulated by its construction standards.

TABLE 4. Temperature Classes Based On Ambient Temperature Range

Ambient Temperature Range		Temperature Class		
Min.	Max.	Gas	Dust	Mining
-55°C <	Ta < 150°C	T3	T200°C	N/A
-55°C <	Ta < 90°C	T4	T135°C	150°C
-55°C <	Ta < 55°C	T5	T100°C	150°C
-55°C <	Ta < 40°C	T6	T85°C	150°C

Operation in aggressive atmospheres

The following components contain non-metallic materials. Confirm compatibility or provide suitable protection if the coupling is to operate in an aggressive atmosphere.

- The hub electrical insulation (if supplied option) – reinforced thermosetting plastic
- Limited end float bearings (if supplied option) – PTFE based plastic

Temperature classification of John Crane's Metastream couplings

John Crane's Metastream metal membrane couplings, supplied in conformance with Directive 2014/34/EU, have to meet the classifications specified in Table 4 when used in accordance with instructions and information supplied.

A series couplings, using the elastomeric type flexible elements, are covered by type examination certificate INERIS 20ATEX3019.

T, L and H series couplings, using the disk type flexible elements, are covered by type examination certificate INERIS 20ATEX3006.

M series couplings, using the diaphragm type flexible elements, are covered by type examination certificate INERIS 20ATEX3018.



John Crane UK Ltd
 361-366 Buckingham Avenue
 Slough
 SL1 4LU
 United Kingdom
 T: +44 (0) 1753 224 000
 F: +44 (0) 1753 224 224
 www.johncrane.com

Declaration of Conformity

EEC Directive 2014/34/EU of 26.02.2014
 and resultant legislation and standards

We, the manufacturers – John Crane UK Ltd, – confirm that the explosion prevention requirements have been implemented for

Metastream® metal-membrane couplings
 and Powerstream elastomeric couplings

Equipment complies with the requirements of directive 2014/34/EU. It is in accordance with article 13. (a) of the directive and the fundamental Health and Safety requirements of Annex II, are fulfilled.

The current Type Examination Certificates for the couplings are:-

'T', 'L' & 'H' Series -	INERIS 20ATEX3006
'M' Series -	INERIS 20ATEX3018
'A' Series -	INERIS 20ATEX3019

The technical documentation is deposited with the designated notified body in accordance with article 13 (b) (ii) of the Directive 2014/34/EU.

Ineris
 AV du Parc Alata
 Verneuil-en-Halatte 60550
 France

Signed:

Date: 14th September 2020

S. Pennington
 (Senior Manager – Engineering Couplings)

**John Crane UK Ltd**

361-366 Buckingham Avenue
Slough
SL1 4LU
United Kingdom
T: +44 (0) 1753 224 000
F: +44 (0) 1753 224 224
www.johncrane.com

Declaration of Incorporation**E.C. Machinery Directive (2006/42/EC)**

Section 1.0 - Machinery Description:
Flexible Power Transmission Ring and Diaphragm Form Membrane Couplings
Types:

'H', 'T', 'L' & 'M' Series

Section 2.0 - Applicable Harmonised Standards
ISO13709 (API 610) for centrifugal pumps
ISO14691 couplings for - General-purpose applications
ISO10441 (API 671) (opt) couplings for - Special-purpose applications

Section 3.0 - Declaration:
We, John Crane declare that under our sole responsibility for the supply of the machinery defined in Section 1.0 above, the said machinery parts are intended to be incorporated into other machinery or assembled with other machinery to constitute machinery as covered by this Directive.

The machinery parts, covered by this declaration must not be put into service until the machinery into which it is to be incorporated has been declared in conformity with the provisions of the Directive.

Signed:

Date: 20th July 2016

S. Pennington
(Engineering Manager - Couplings)

T SERIES FLEXIBLE MEMBRANE COUPLING FOR API APPLICATIONS

Installation, Operation & Maintenance Instructions



North America	Europe	Latin America	Middle East & Africa	Asia Pacific
United States of America	United Kingdom	Brazil	United Arab Emirates	Singapore
Tel: 1-847-967-2400	Tel: 44-1753-224000	Tel: 55-11-3371-2500	Tel: 971-481-27800	Tel: 65-6518-1800
Fax: 1-847-967-3915	Fax: 44-1753-224224	Fax: 55-11-3371-2599	Fax: 971-488-62830	Fax: 65-6518-1803

If the products featured will be used in a potentially dangerous and/or hazardous process, your John Crane representative should be consulted prior to their selection and use. In the interest of continuous development, John Crane Companies reserve the right to alter designs and specifications without prior notice. It is dangerous to smoke while handling products made from PTFE. Old and new PTFE products must not be incinerated. ISO 9001 and ISO14001 Certified, details available on request.